

Installation Instructions for the Urban Mid-Fold Door

Refer to the shop drawings to see the specifics that are particular to the door you are installing because we custom design our doors for each customer's order, and the images below only represent the basic framework of the Urban Mid-Fold.

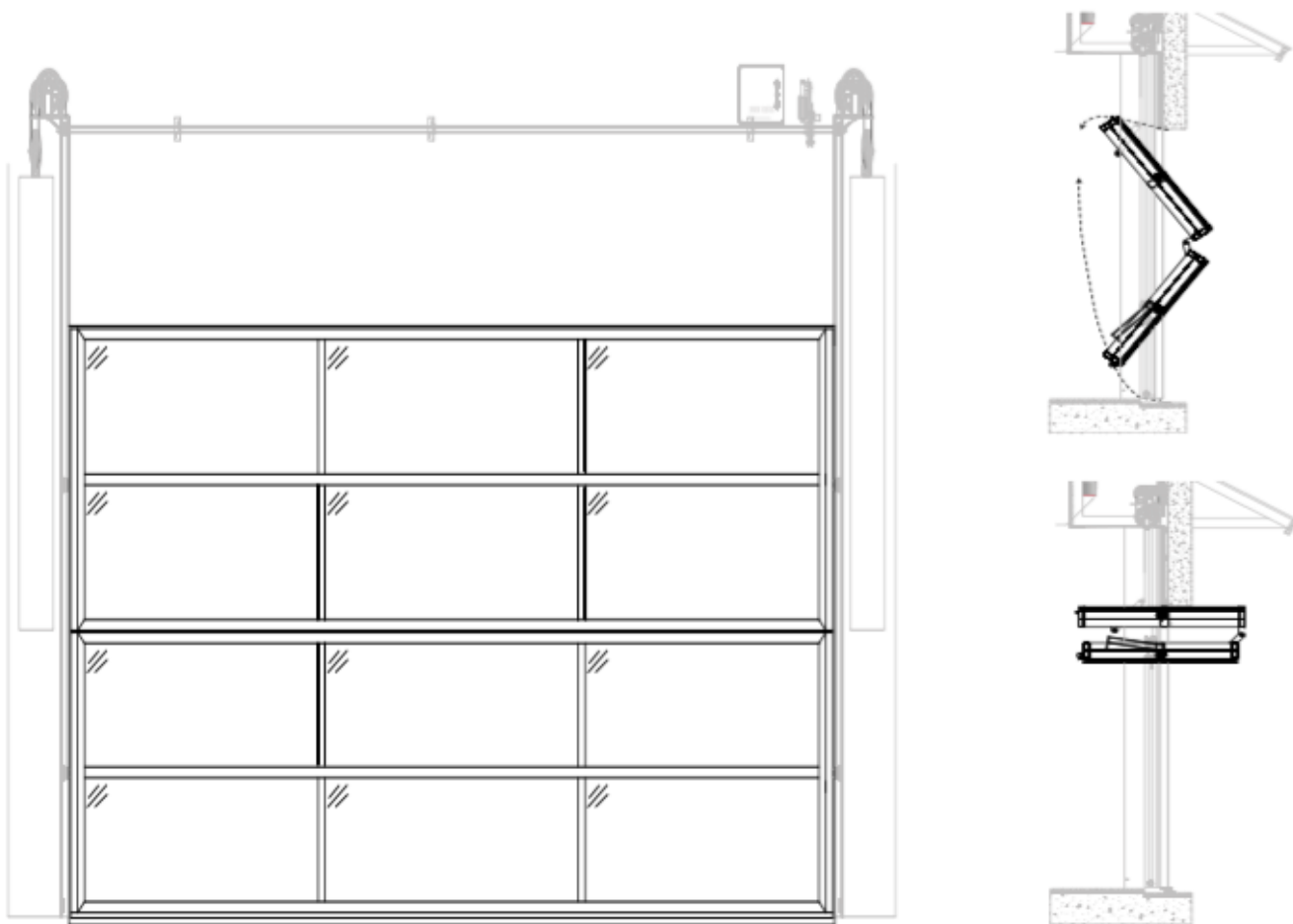

Table of Contents

Process 1- Preparations1

Bring these tools and materials

Examine the area

Set up a work zone

Prepare the pieces

Process 2- Positioning the Door.....2

Set the door inside

Install the link arms

Connect the cables

Raise the door

Process 3- Fastening the Operating Channels.....3

Place the operating channels

Route the cables

Fasten the link arms

Align the door

Fasten the operating channels

Process 4- Installing the Glass.....5

Apply the tape and seat the glass panels

Insert the glazing caps

Process 5- Hanging the Counterweights and Balancing the Door.....7

- Hang the weights
- Balance the door

Process 6- Engaging the Motor to the Door8

- Connect the trolleys
- Install the torsion bar
- Align the cam pins

Process 7- Installing the Threshold and the Top and Bottom Seals..... 10

- Install the top seal
- Install the threshold
- Install the bottom seal

Process 8- Programming the Motor and Covering the Counterweights 12

- Install and program the motor
- Cover the counterweights
- Test the door

Troubleshooting 13

What you need to know before you begin:

- Only factory trained installers may install Full View Door Company doors because only they have the training to install them correctly, which is critical for quality and safety.
- Make sure you obtain and follow the shop drawings in each shipment because they alone specify each door's particular configuration. Do not begin an installation without them.
- Never substitute the hardware and components that Full View Door Company Doors provides. If you need new parts, contact Full View Door Company at the number below.
- Use the appropriate tools, equipment, and personal protective gear to install the door so that you ensure a safe and quality installation.
- Contact Full View Door Company if you need technical support: 866-890-1776

Process 1- Preparations

1 Bring these tools and materials

- A. Tape measure
- B. Slip-ring pliers
- C. Rubber mallet
- D. Pull-type chain hoist
- E. Pry bar
- F. Power drill and drill bits- (Phillips, flat-head, sockets, etc.)
- G. Laser level or a long level (A laser level works best.)
- H. Sockets and wrenches
- I. Utility knife or sheers
- J. Wooden shims
- K. Thread-locking compound
- L. Heavy duty C-clamps

M. Glazing suction cups

2 Examine the area

A. Compare the shop drawings to the doorway to ensure it has these things:

- A finished-floor height that matches the drawings
- Space for the door to open and close without hitting the floor or the ceiling's furnishings
- Space in the doorway for the door
- Space for the counterweights to move without contacting other things
- Space for the cables to run without rubbing anything
- Space on the doorjamb and at the ceiling for the operating channels
- Doorjamb that are the same material as those in the shop drawings

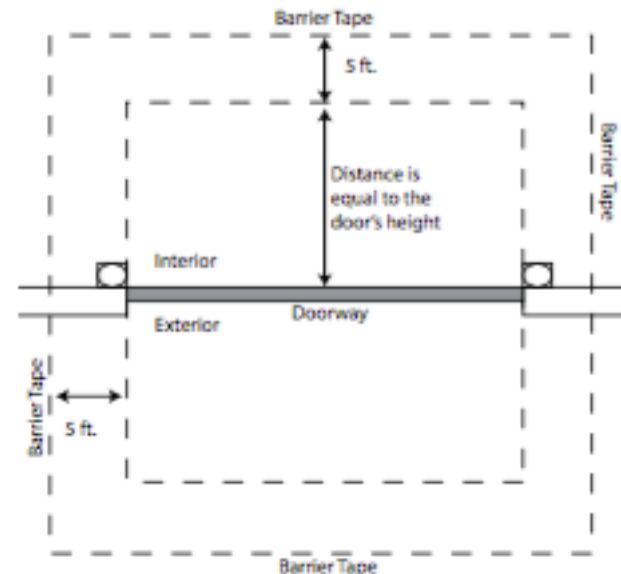

3 Set up a work zone

- A. Let other construction workers in the area know that the doorway will be inaccessible from the time you begin until you complete your installation. No one should run hoses or cords through the doorway because you will need total clearance.
- B. Set up a safety zone according to the illustration.

4 Prepare the pieces

- A. Thoroughly examine the cables to make sure they are in good condition. Do not install them if they have any damage.
- B. Contact Renlita if you need a replacement cable.
- C. Place the counterweights and the operating channels inside the doorway.

- D. Place the glass panels and glazing caps out of the way, if you have them, to protect them from damage.
- E. Insert the side seals into the operating channels.

Process 2- Positioning the Door

1. Set the Door inside

A. Lift it from the shipping truck with a forklift by running straps or chains through the middle of the folded leaves, similar to the illustrations. Use a padding material with a chain so that it doesn't scratch the paint.

B. Place the door flat on the ground inside the doorway so that the axles are on the inside when you raise it.

C. Set the door on a soft material so that you will not accidentally mar the finish. (E.g. cardboard or plywood)

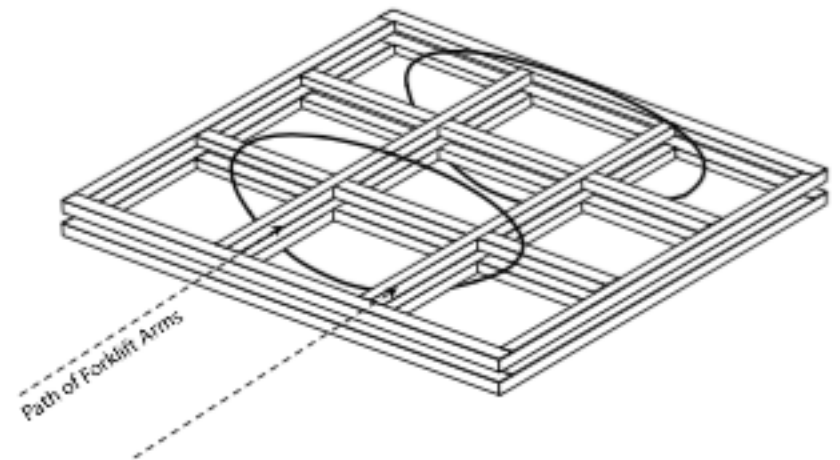

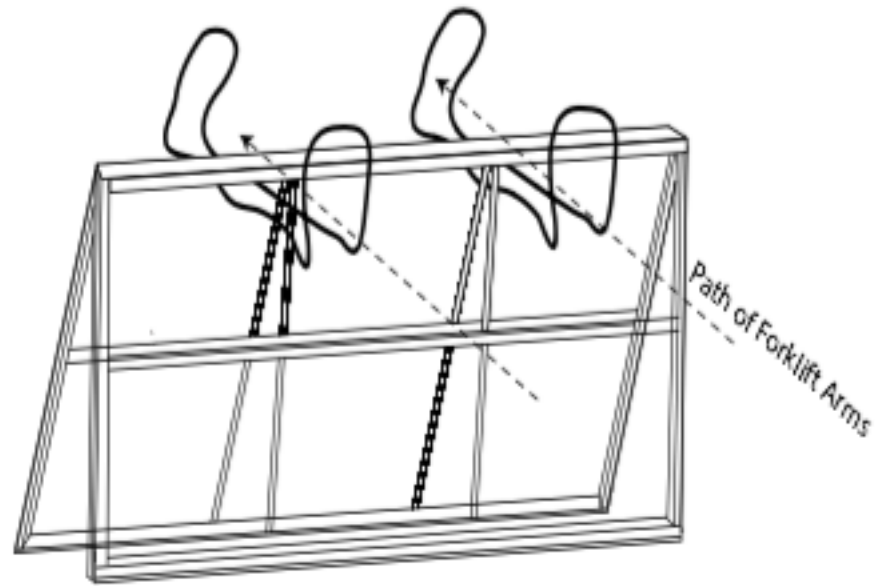

2. Install the link arms

A. Install the link arms onto the door while it is on the ground.

B. The offset hole of the link arms must face the interior of the door after the door is raised.

C. Always use an open or box wrench, never an adjustable one, to tighten the nuts and bolts. Do not tighten the bolts excessively.

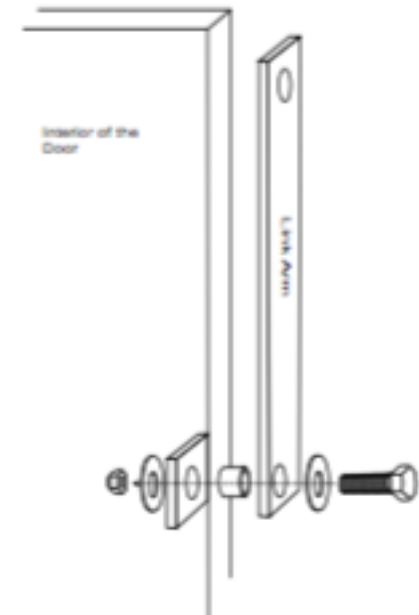

* CAUTION: The threaded ends of the bolts must always protrude on the door's side of the lug, rather than the channel's side, so that they don't rub the cables.

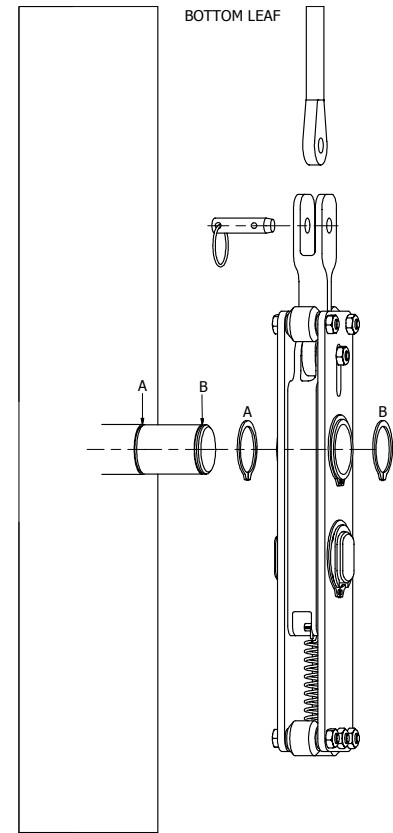
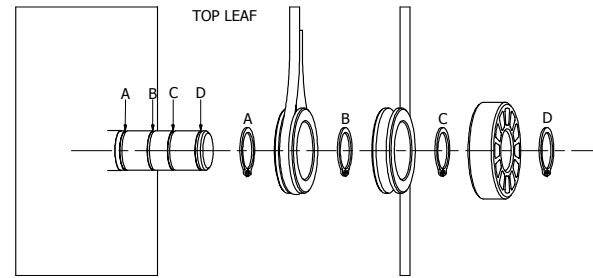

3. Connect the cables

A. Lubricate the axles with the lubricant in the shipment, then join the cables, rollers, and slip rings to the axles by following the sequence below. Notice that the bottom cables will be offset on both sides, which prevents them from rubbing the top cables.

4 Raise the door

A. Place two counterweight plates in the threshold to give you space to level the door with shims after you raise it.

B. Use a chain hoist or a forklift to raise the door; use padding to protect the finish on the door.

* CAUTION: Ensure that the hoist or the forklift is rated to lift the door's weight.

C. Make sure the panels are vertically plumb. Insert shims between them, and clamp them so that they remain vertically plumb while you finish the installation.

(See the illustration below.)

D. Refer to the shop drawings to know how high off the finished floor the door needs to be.

* NOTE: Make sure your clamps will not scratch the powder coating on the door.

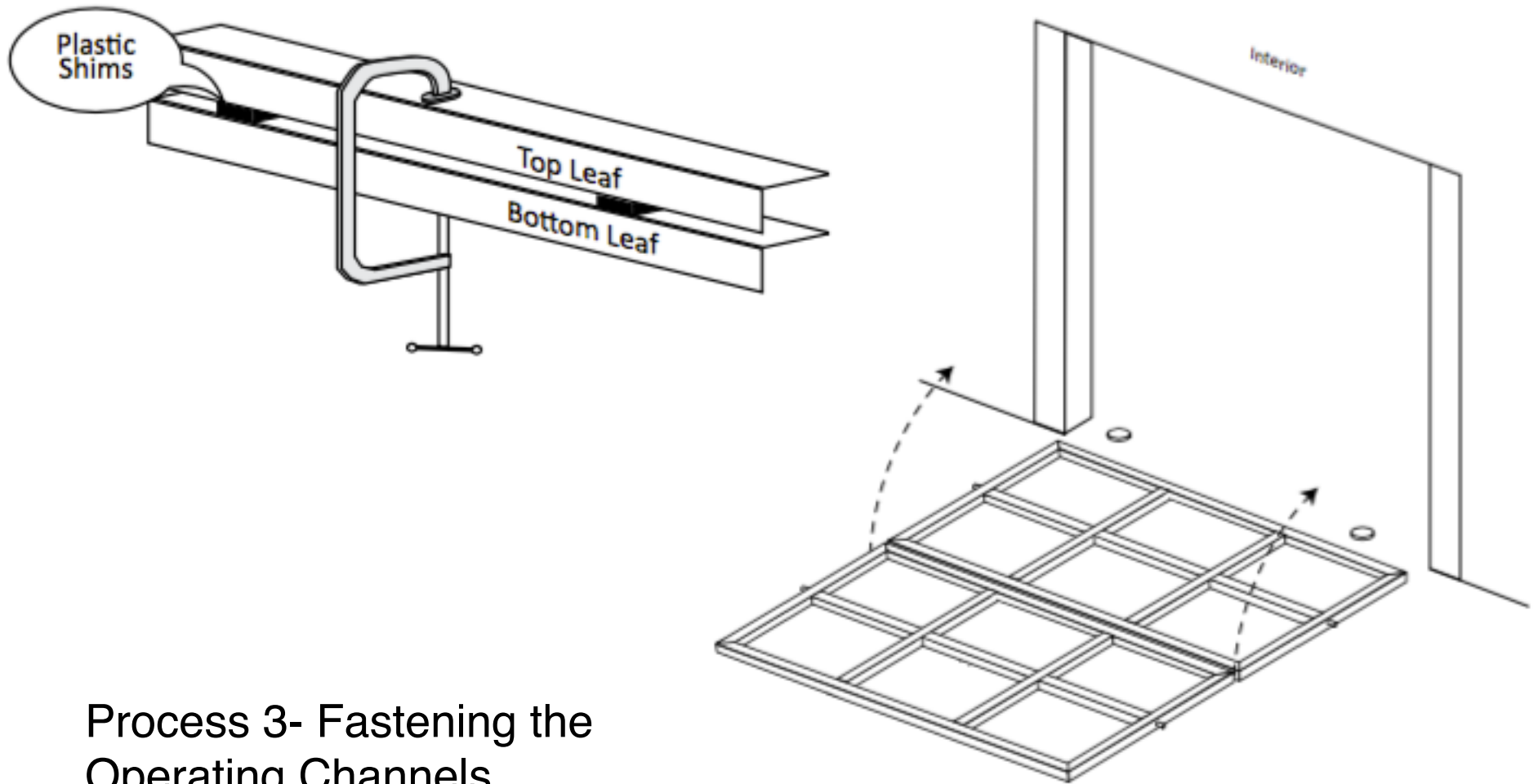

Process 3- Fastening the Operating Channels

1. Place the operating channels

A. With the door in place, position the operating channels according to the shop drawings, and temporarily fasten them with clamps.

B. Make sure the side seals on the operating channels are touching the door so that no light can shine through, but not so hard against it that the seals are compressed.

C. Adjust the operating channels, not the door, if the seals allow light to shine through.

2. Route the cables

A. Route the cables through the channels of the rails and over the pulleys, according to the shop drawings.

B. If you are installing a set of doors that will share a counterweight, route the shared cable for one door, and after you have fastened its operating channels, route the cable for the second door. The cable will be draped between them for you to hang the counterweight from its center.

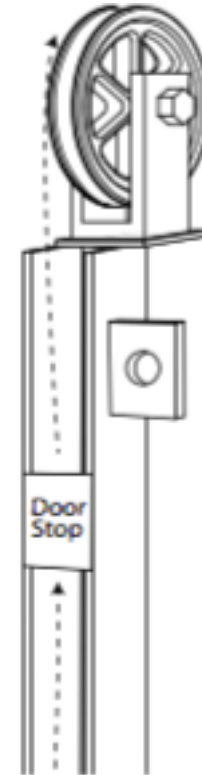

3. Fasten the link arms Align the door

A. Fasten together the link arms on the door and the lugs on the operating channels according to the illustration.

B. Make sure you are placing the bolts through the link arms.

centered holes on

4. Align the Door

A. Install the door to the specific dimensions on the shop drawings, even if the floor is not finished.

* All dimensions in the shop drawings show the door's position relative to the finished floor.

B. Center the door so that it has equal spacing on the right and left. Make sure light does not shine through the side seals.

C. Level the door with a leveling device and shims.

D. The space between the bottom of the door and the finished floor must at least be what you see in the shop drawings.

E. Make sure the spacing on the top matches the shop drawings.

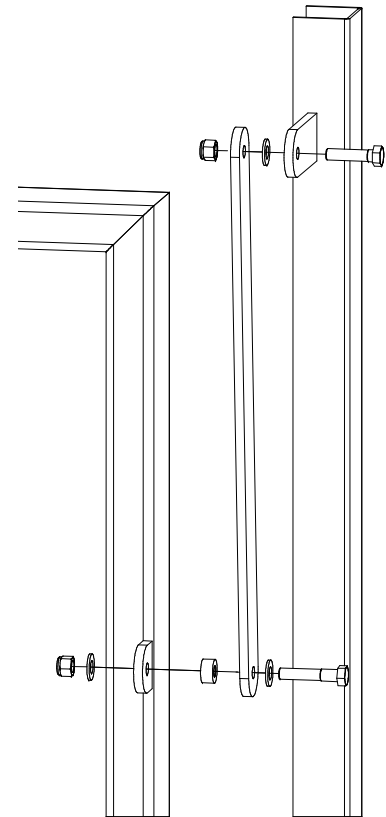

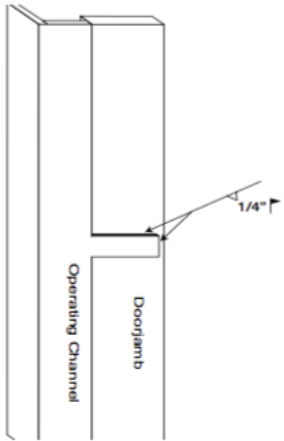

5. Fasten the Operating Channels

A. Use the hardware in the shipment to permanently mount the operating channels onto the doorjamb according to the shop drawings.

B. These illustrations show the standard methods for fastening the operating channels to wooden, steel, and concrete doorjamb. Refer to the shop drawings to know which applies to your installation.

For steel doorjamb-

Weld the top and side edges, and make the welds at least 1/4" thick.

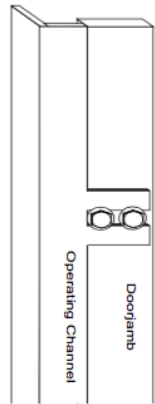

For wooden doorjambs-
Install the lag screws from the shipment according to this illustration; we will send washers in the shipment if the lag screws need them.

For concrete doorjambs-
Install the anchors from the shipment according to this illustration;
we will send washers in the shipment if the anchors need them.

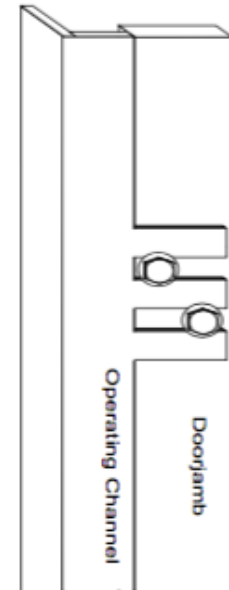

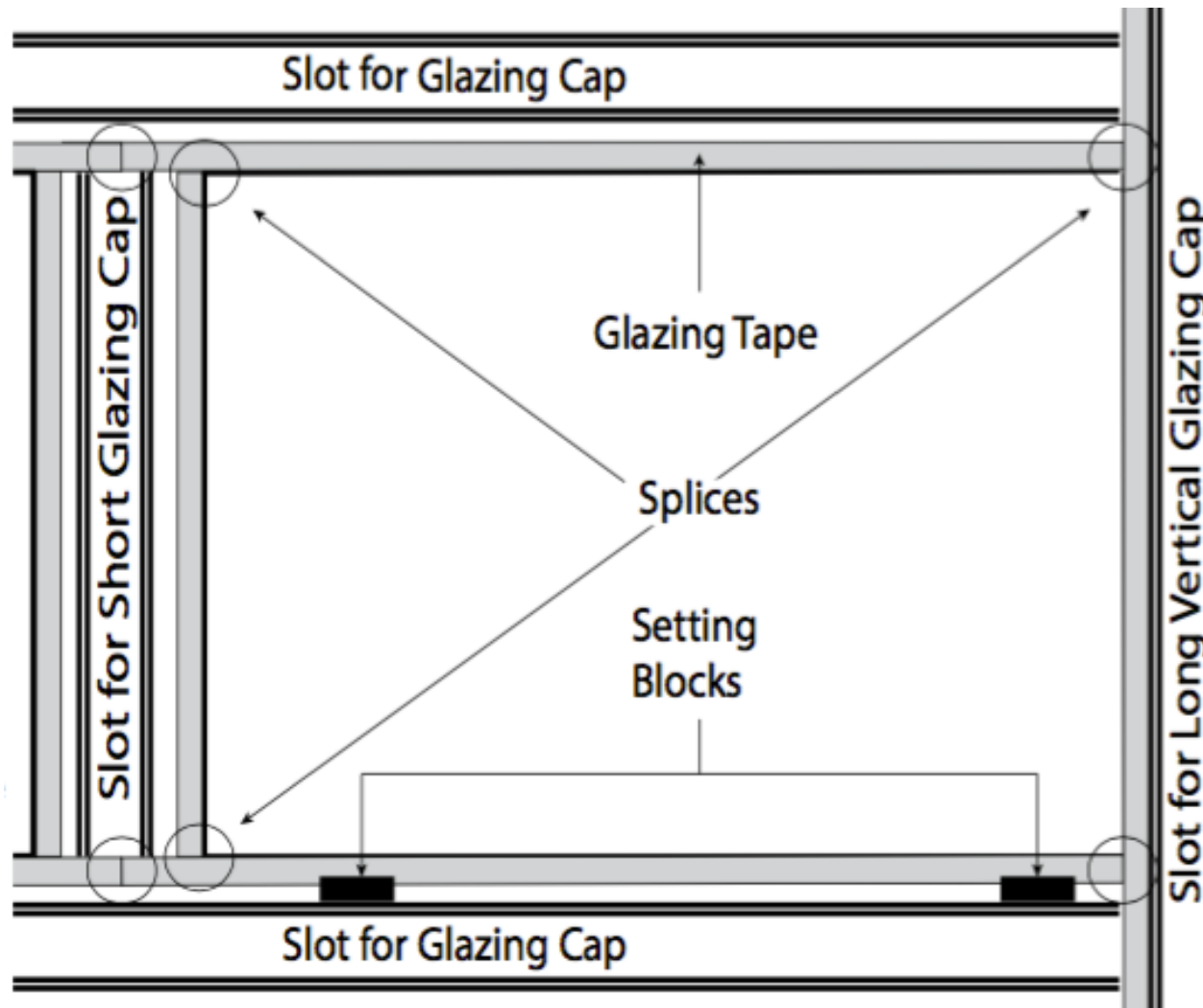

Process 4-
Installing
Glass (For
doors with
cladding, skip to Process 5)

the

1. Apply the tape and seat the glass panels

* NOTE: Only install the glass in dry weather and in temperatures above 40° Fahrenheit, or the tape will not adhere to the glass or the door.

A. Thoroughly wipe the areas where the tape will lie with denatured alcohol so that dust and moisture do not inhibit the tape's adhesiveness.

* NOTE: Do not substitute another adhesive in place of the tape in the shipment, unless the shop drawings indicate otherwise.

B. Apply the double-sided glazing tape to the inner edges of the mullions and to the frame where the panels will sit. Leave the protective film on the tape until you're ready to seat the panels. Do not lay the tape on a dirty surface because it will pick up dust.

C. Splices in the tape make the glass less likely to stick, so only splice the horizontal strips of tape where the mullions meet the frame and where the vertical cap grooves meet the mullions.

(See the circles in the illustration.)

D. Apply the sealant in the shipment (Dow Corning 995 Sealant) to every splice in the tape, and place a setting block where each corner of the glass panels will sit.

E. Refer to the shop drawings to know which side of the glass should face the exterior.

F. Use suction cups to carry the glass panels, and seat them on the setting blocks. Press them firmly against the tape; the tape will adhere to the glass instantly.

G. Install the short glazing caps between the panels you have seated to hold them in place as you seat the others.

* NOTE: Make sure your suction cups are rated to carry the weight of the glass panels.

2. Insert the glazing caps

A. Trim the ends of the caps' seals at a 45° angle so that their seals will not push up the seals of the caps they intersect. (See the illustration on the side.)

* NOTE: Do not trim the caps because they have been fitted in the factory.

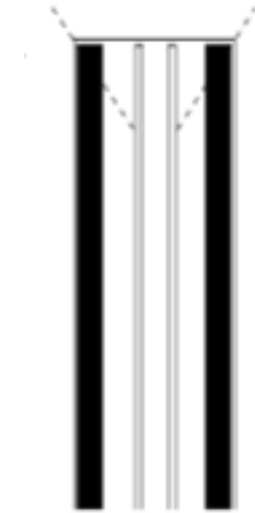

B. Cut a gap in the seals of the long, horizontal caps where the shorter caps will intersect them. Cut a similar gap in the seals of the long, vertical caps where the long, horizontal caps will intersect them.

(See the circles in the illustration below.)

C. Install the caps by aligning their grooves to the inside of the mullions' grooves and tapping them in place with a rubber mallet. The caps will have labels to indicate their place on the door.

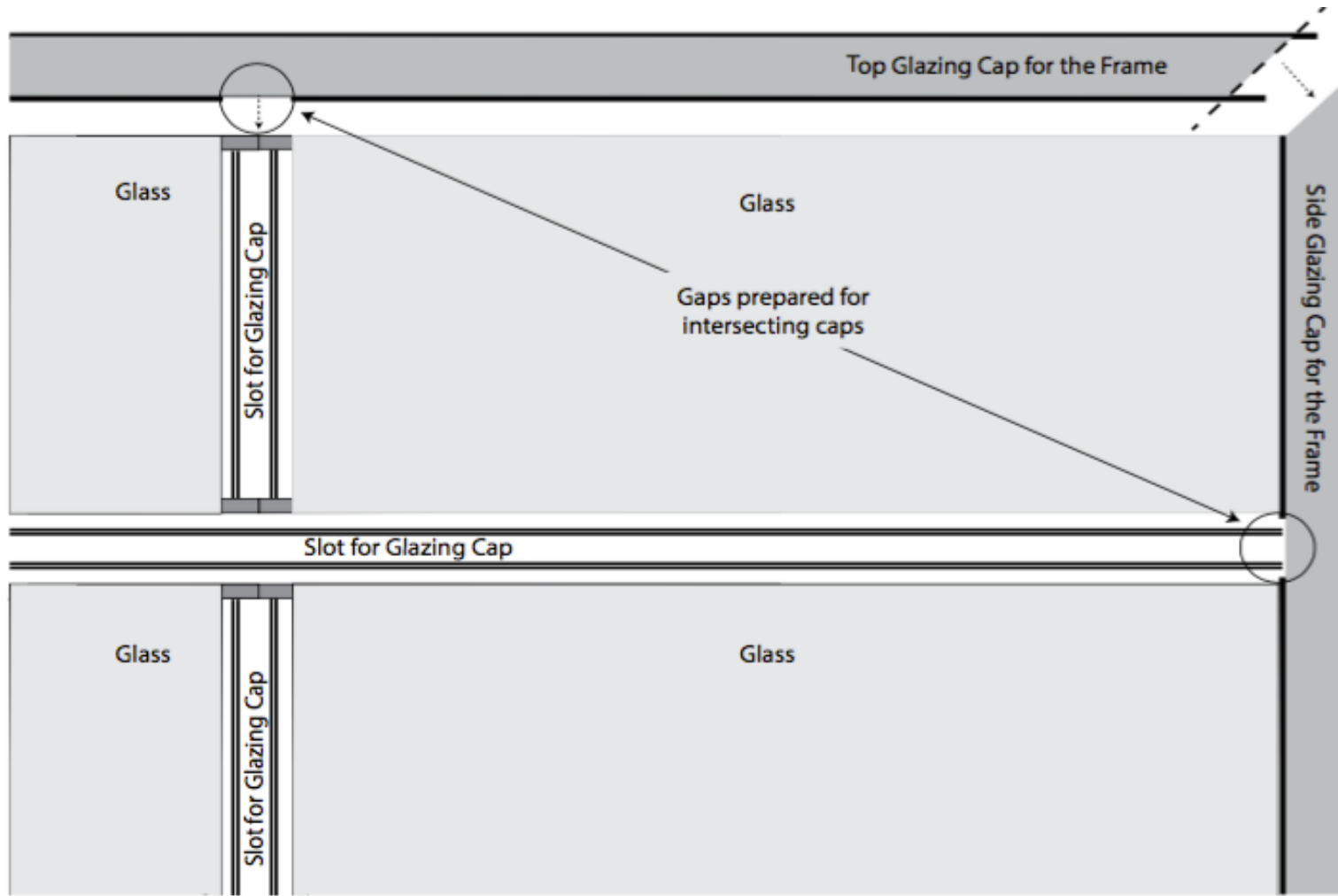

Process 5- Hanging the Counterweights and Balancing the Door

1. Hang the Weights

* CAUTION: You must install the glass (or cladding) before you hang the counterweights because they are designed to offset the weight of the door with its glass or cladding.

- A. Refer to the shop drawings to ensure that you hang the weights properly.
- B. Make sure to properly align the pulleys over the operating channels so that the cables do not rub anything after you hang the weights.
- C. Use a chain hoist or a forklift to raise the counterweights to the ends of the cables.
- D. Always bring the counterweights up to the cables, leaving the door closed. Never try to bring the cables down to the weights by opening the door.

* Welding a temporary lug on each of the weights gives your chain or strap something to catch as you raise the weight. (Cut off the lug after you hang the weights.)

* When hanging a shared counterweight, hang it in the middle of the shared cable, according to the shop drawings.

2. Balance the door

A. Remove the clamps that are holding the panels vertically plumb and the shims that are underneath the door so that you can open it.

* If the shims are wedged too tightly to slide out, loosen the link arms, and use a pry bar to lift the door high enough to slide them out. Tighten the link arms before you proceed.

* CAUTION: You must ground your welder directly to the counterweight that you are adding weight to so that the electrical current does not run through the cable and melt its core.

B. Check the balance of the door by opening it halfway to see if it suspends without being inclined to open or close on its own.

a. If the door closes on its own, the counterweights are not heavy enough, and you need to weld on extra plates.

b. If the door opens on its own, the counterweights are too heavy.

c. Also, the door is balanced if you can open and close it with the same amount of pressure.

C. Fully open and close the door to ensure nothing hinders the counterweights or the door's travel. Fix any obstructions before you proceed.

D. To open the door manually, pull the bottom toward the interior, and slowly guide it upward until it gently rests in its open position. Close the door by gently pulling the bottom down until the door closes fully.

* NOTE: Be careful not to allow the door to slam open or shut because that will eventually cause damage to the door, which may make it dangerous to use.

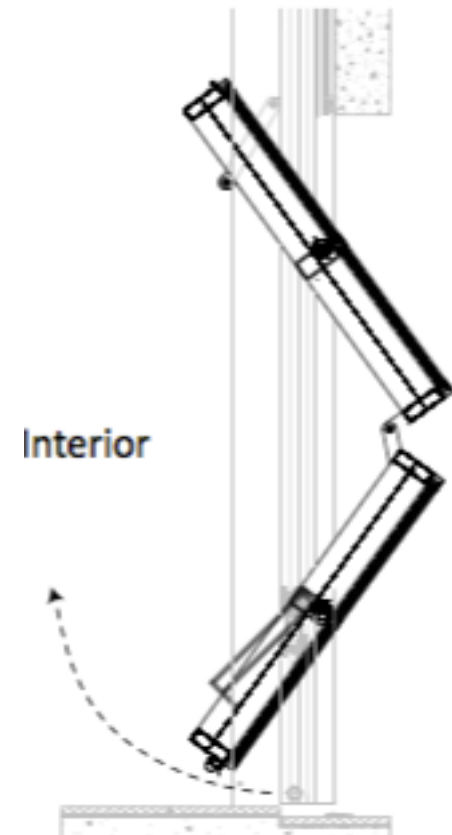

Process 6- Engaging the Motor to the Door (For manual doors, skip to process 7)

1. Connect the trolleys

A. With the door closed, insert the cam pins into the bottom of the cam tracks on the door.

B. Slide each trolley up or down to where its pin sleeve lines up with its cam pin.

C. Insert the cam pin into the pin sleeve, and secure it with the cotter pin.

* The motor will operate the door by the trolleys.

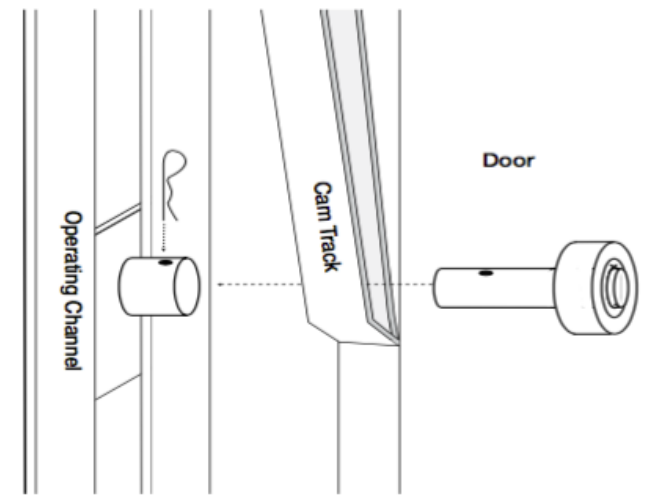

2. Install the torsion bar

A. Check the shop drawings to see its specifications for placing the motor and installing the torsion bar.

B. Cut the torsion bar to fit between the axles on the inner sides of the operating channels. (See the dotted line.)

C. Use the adjustment coupler, the fixed coupler, and the center support bracket to attach the bar to the axles. Level the bar before you secure it.

D. Install the adjustment coupler on the same side as the motor so that you do not have to move a ladder back and forth when you align the cam pins; and only slightly tighten the adjustment coupler because you will need to turn it by hand when you align the cam pins.

3. Align the cam pins

A. To align the cam pins, measure the distance from the bottom of a cam track to the center of a cam pin for

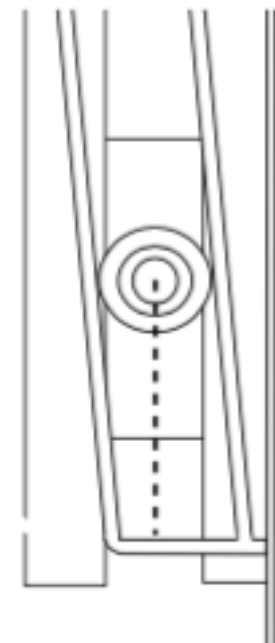

each side of the door (See the dotted line.)

B. Then rotate the adjustment coupler to move the trolley on that side up or down so that its cam pin is aligned with the other one.

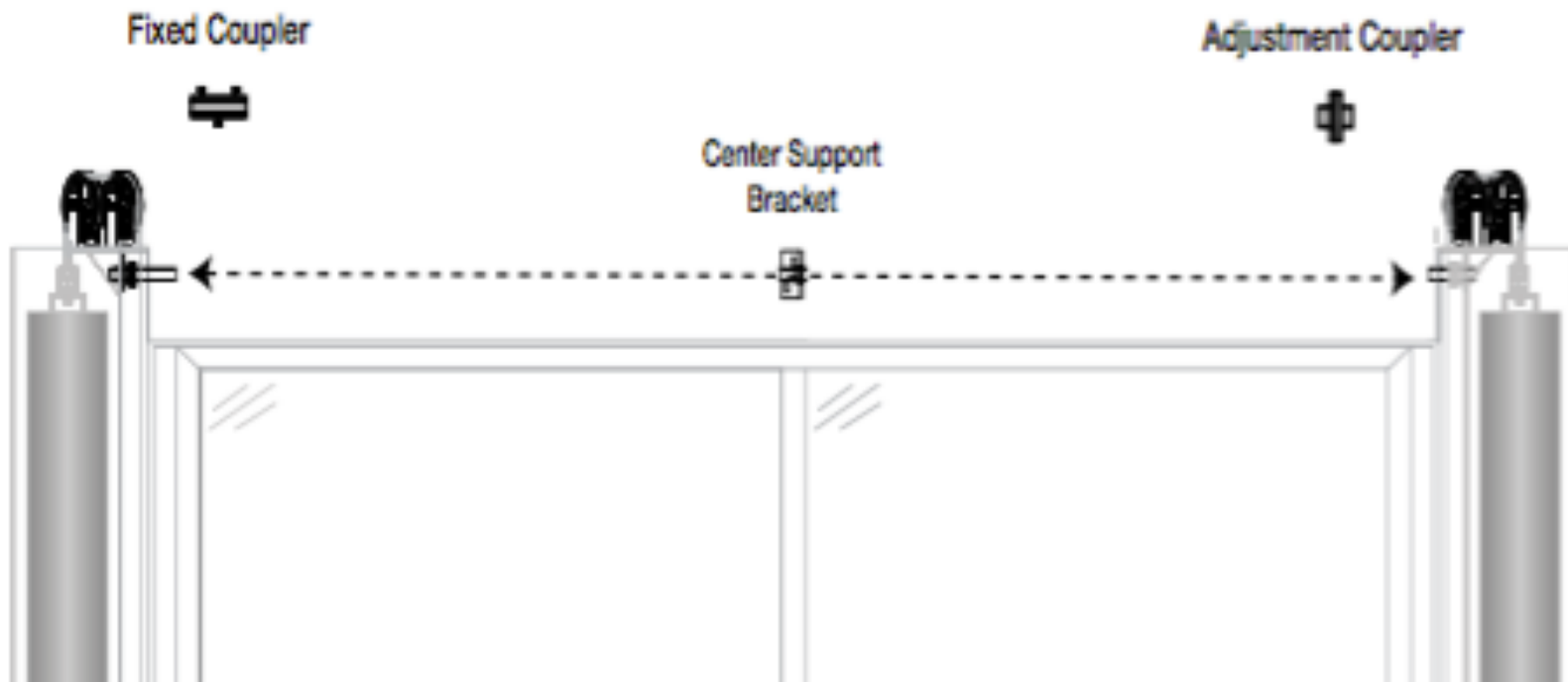

C. After you align the cam pins, apply a thread-locking compound to the adjustment screws on the adjustment coupler, and tighten them.

Process 7- Installing the Threshold and the Top and Bottom Seals

1. Install the top seal

A. Cut the gasket for the top seal to fit snugly between the side seals as it lies across the top of the door.

B. Insert the gasket into the metal retainer, and screw the retainer into the top of the door frame according to the illustration. Make sure no light penetrates between the top and side seals.

C. Trim the retainer if it is necessary.

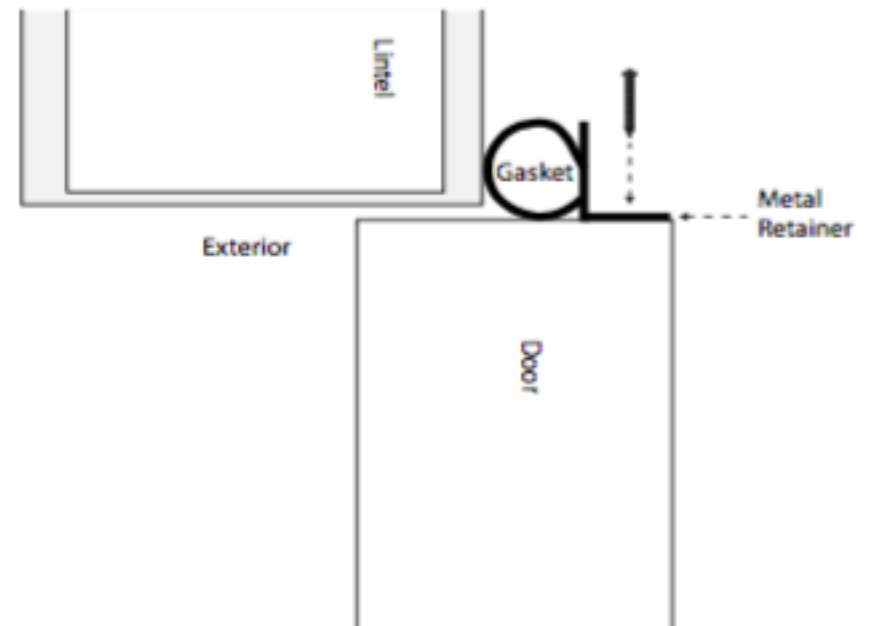

2. Install the threshold

A. Measure the opening between the jambs, and cut the threshold 3 inches longer than the opening.

B. Cut a 1 inch notch out of the short side on the ends of the threshold. Seat the notches of the threshold on the interior corners of the doorjamb, and operate the door to make sure the bottom seal and the hump on the threshold make good contact without inhibiting the door's movement.

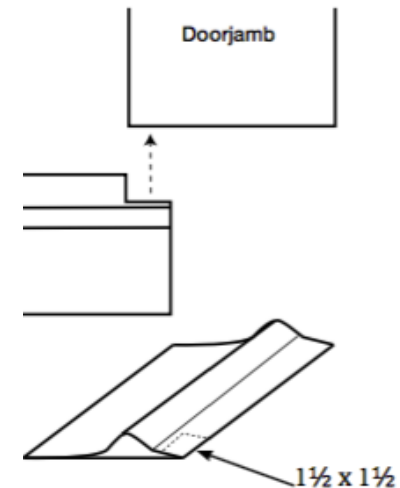

C. Through each of the predrilled holes in the threshold drill pilot holes in the floor for the screws. Move the threshold, and apply a bead of structural adhesive that is 5/16 of an inch thick between the pilot holes where the threshold will lie.

D. Place the threshold in its position, and seat the screws.

* NOTE: If you need to splice the threshold, join the pieces where screws will be no more than 8 inches from both sides of the splice.

4. Install the bottom seal

A. Install the bottom seal by opening the door to access the bottom of the frame, and install the seal according to the drawings below.

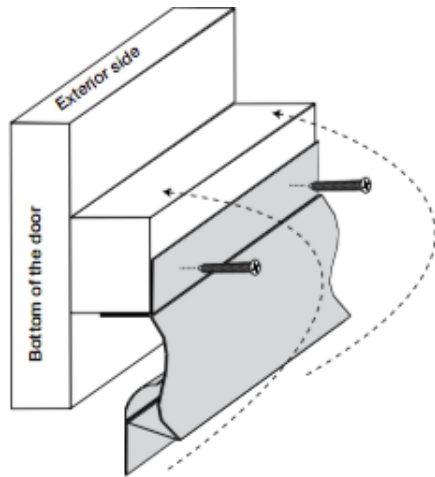

B. The drip edge of the gasket should face the exterior side.

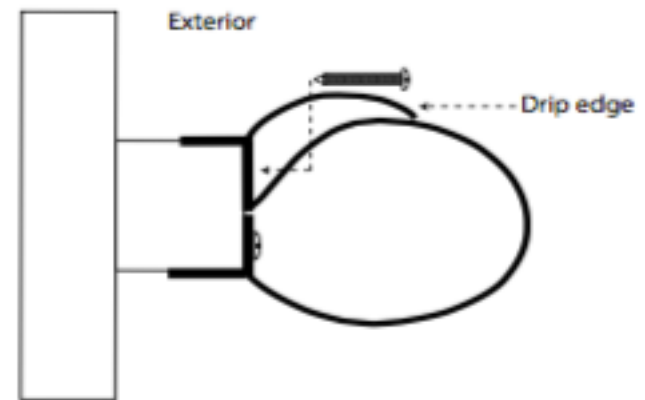

Process 8- Programming the Motor and Covering the Counterweights

1. Install and program the motor

A. Install the motor as the shop drawings specify.

B. Program the motor according to its installation manual.

C. Ensure that the motor closes the door vertically plumb.

2. Cover the counterweights

A. Follow the shop drawings to see how to install the covers for the counterweights.

3. Test the door

- A. Operate the door 5 to 10 times to ensure it works properly.
- B. Ensure that the seals are making good contact and that the door closes and opens to the dimensions in the shop drawings.

Troubleshooting

A. The door is difficult to open or close.

- a. Check the balance of the door and the counterweights; add or remove weight to the counterweights if it's necessary.
- b. Inspect the perimeter seals, and verify that they are not causing excessive friction.
- c. Ensure that the link arm bolts are not so tight that they resist the rotation of the link arms, which is necessary to raise the door; loosen the bolts if necessary.
- d. Ensure that the counterweights can travel without contacting anything.

B. The door stops and returns to the open position when I try to close it.

- a. Make sure that nothing is obstructing the motor's safety
- b. Check the motor's control panel because it may indicate the problem.
to the motor's installation manual for a diagnosis
- c. Make sure the wiring in the control station is correct.

Refer

C. The door stops and returns to the closed position when I try to open it.

a. Make sure the cam pins are aligned; loosen the adjustment coupler on the torsion bar if you need to realign them. (See Process 6, number 3)

D. The door will not operate.

a. Verify that power is getting to the motor and/or its control unit.

b. Check the wiring in the control station.

c. Make sure the photo eyes are connected and working

d. Make sure the motor is engaged to the torsion bar.

E. The door makes a “bumping” noise when I operate it.

a. Lubricate the surfaces between the cable thimbles and the axles with bearing grease.

b. Make sure the trolley chains have a little deflection in them. Adjust each chain's tension by turning the nuts on the bolts that connect the trolleys to the chains.

c. Inspect and lubricate the pulley bearings.

F. The Door Does Not Close Completely

a. Check the settings for the travel limit that the motor calibrated.

b. Make sure nothing is binding the bottom seal.

c. Make sure the bottom of the door is not rubbing the floor.

d. Make sure the link arms are facing the right direction.(See Process 2,Number 2)

G. The door does not open completely

opening stop.)

- a. Check the door stops to make sure the door is meeting them and fully. (See Process 3, Step 2 to find the location of the door stop.)

- b. Make sure the door is not colliding into the lintel.

- c. Make sure nothing is keeping the counterweights from lowering fully.

H. ZAP Motor is operating very slow.

- a. The motor may still be calibrating the door's movement. Refer to the motor's manual for reset instructions and limit programming.

- b. Make sure nothing is obstructing the door.

- c. In the event of power loss for more than 2 hours, the internal memory module will need to recalibrate the door's limits. Operate the door to fully open and fully closed, and the motor will resume normal operation.

Service and Repair

1. Replacing a glass panel

a. From the outside, one person should hold the panel with suction cups.

b. From the inside, another person should cut the double-sided tape by sliding a utility knife around the edges of the panel, releasing it for the person on the outside to remove.

c. Thoroughly clean the mullions with denatured alcohol, scraping the excess residue if it's necessary. Do the same on the glass panel if you intend to reuse it.

d. Reapply the tape according to the instructions in Process 4.

2. Replacing the trolley bearings

- a. Slide the trolley down to the service port at the bottom of the operating channel.
- b. Disconnect the trolley from the chain by unscrewing the tensioner bolt at the bottom and unhinging the chain link at the top. Remove the U-shaped fastener from the chain link so that you can slide the chain pin out of the trolley's tab.
(See the illustration.)
- c. Pull the trolley out at the bottom of the channel.
- d. Slide the old or broken bearings off, and slide the new ones on.
- e. Reinsert the trolley into the channel, and reconnect the tensioner bolt and the chain link.

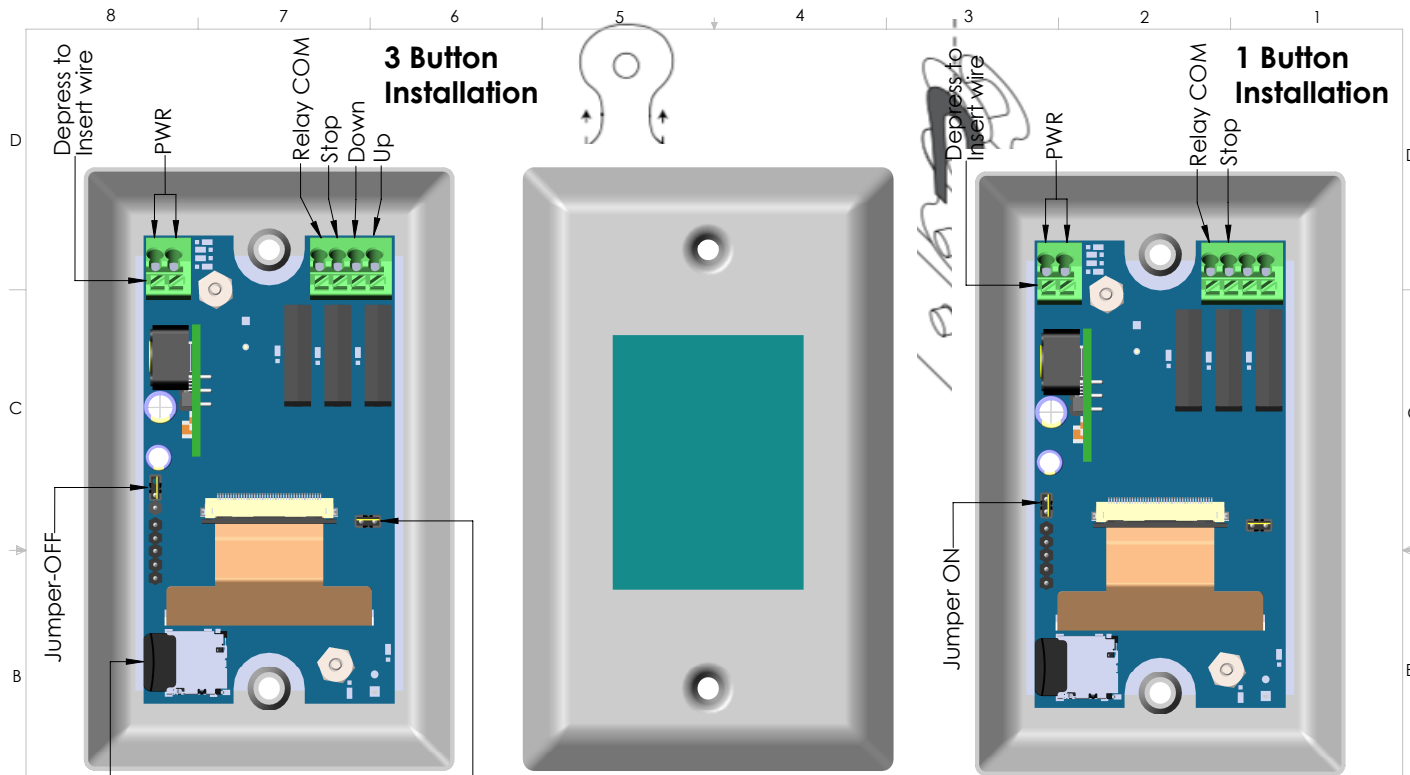

Micro SD Card Graphic Storage

Jumper ON
Number Pad Enabled
Jumper OFF
Number Pad Disabled

DATE	REV.	DESCRIPTION	ECO #	ENG.	APPROVED
07/22/15	A	ORIGINAL RELEASE	1001366	BH	
08/26/15	B	Number Pad and SD Card Added	1001366	BH	
09/29/15	C	1Button and 3 Button Call out	1001366	BH	
00/00/15	D	4th RELEASE	1001xxx	BH	

THE INFORMATION CONTAINED IN THIS DRAWING IS THE SOLE PROPERTY OF APPLIED DIGITAL, INC. ANY REPRODUCTION IN PART OR WHOLE WITHOUT THE WRITTEN PERMISSION OF APPLIED DIGITAL, INC. IS PROHIBITED.

ITEM NO.	PART OR IDENTIFYING NO.	NOMENCLATURE OR DESCRIPTION	MATERIAL SPECIFICATION	QTY REQD
PARTS LIST				
UNLESS OTHERWISE SPECIFIED DIMENSIONS ARE IN INCHES		CAD GENERATED DRAWING, DO NOT MANUALLY UPDATE		
TOLERANCES ARE:		APPROVALS		
FRACTIONS	DECIMALS	ANGLES	DRAWN	DATE
+	.XX+ .XX + 1	.XXX+.XXX	BH	09/29/15
MATERIAL		CHECKED		
FINISH		RESP ENG		
DO NOT SCALE DRAWING		MFG ENG		
		QUAL ENG		
		SCALE		

Applied Digital, Inc.

99917000007
Garage Door Opener

SIZE A DWG. NO. 1839 REV. C

SHEET 1 OF 1

Renlita Touchpad Door Controller Keypad Operation

When the Keypad Enable jumper is installed and the system is in idle (main logo displayed) pressing anywhere on the screen will bring up a 10 key pad for entering a security code.

When the security code has been entered, then press the ENTER key. If the code is correct, the door control screen will show. If the code is incorrect, the unit will beep and the code may be entered again.

If the keypad is showing and a key is not pressed for 20 seconds, the system will revert back to the idle screen.

The default factory code is the lower 4 digits of the serial number.

Whenever the default factory code is entered, the user will be asked if they would like to set a passcode. This will always be the case, even if a user code has been entered.

Pressing NO will proceed to the door control screen.

Pressing YES will show the 10-key pad. The user will then enter a code, up to 4 digits, and press Enter. Then a confirmation screen will ask to accept or cancel the new code.

ACCEPT will save the new passcode.

CANCEL will proceed to the door control screen without saving a code.

When the user wishes to change the code, enter the factory default code and repeat the process.

Important: the user code can be up to 4 digits, but 0000 is not acceptable. Any leading zeros will be ignored.

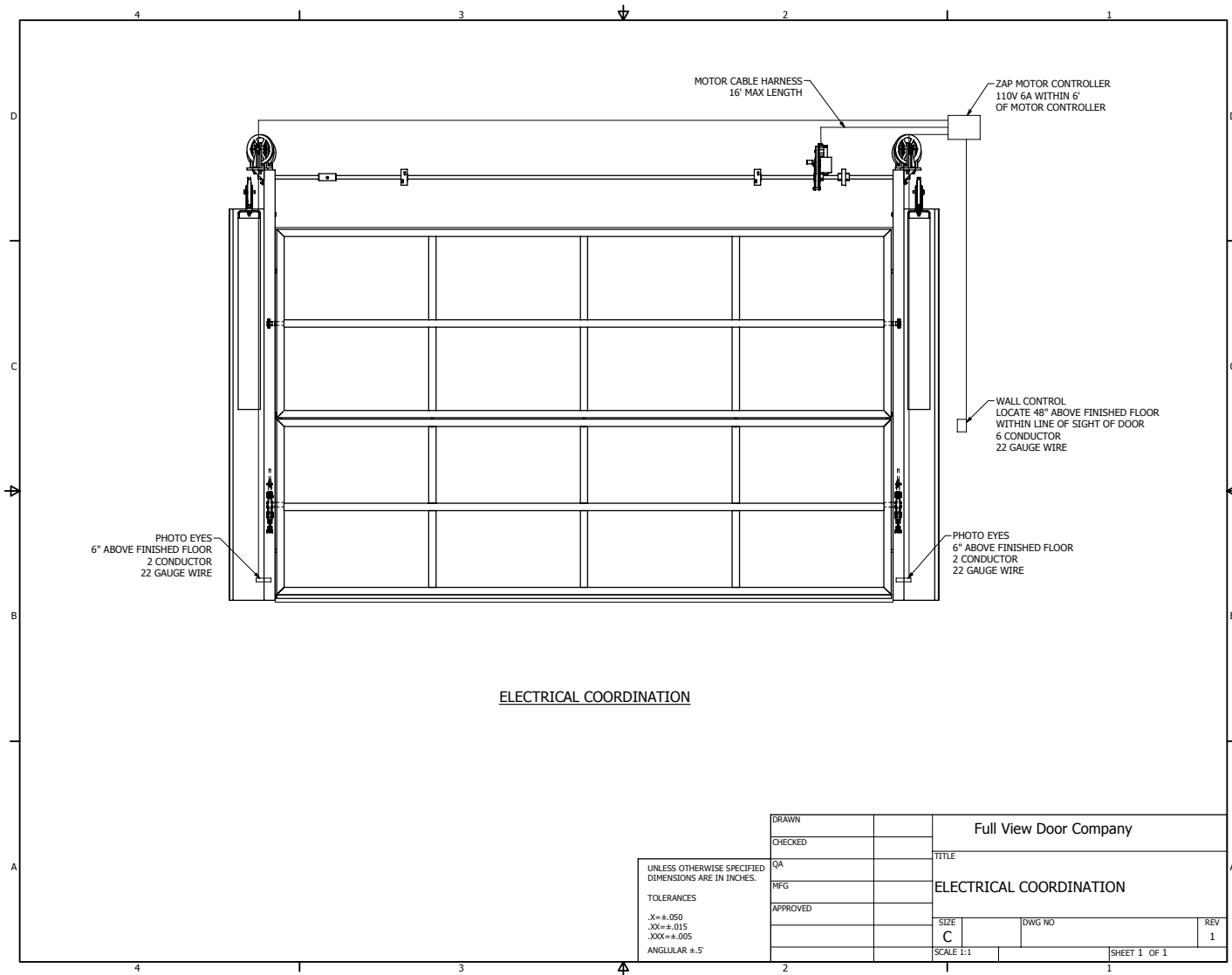

UNLESS OTHERWISE SPECIFIED
DIMENSIONS ARE IN INCHES.

TOLERANCES
 .X= ±.050
 .XX= ±.015
 .XXX= ±.005
 ANGULAR ±.5°

DRAWN		Full View Door Company	
CHECKED		TITLE	
QA		ELECTRICAL COORDINATION	
MFG		SIZE	DWG NO
APPROVED		C	1
		SCALE 1:1	SHEET 1 OF 1

