

Vista Vertical Bi-Fold Installation Instructions

Refer to the shop drawings to see the specifics that are particular to the door you are installing.

We custom design our doors for each customer's order, and the images below only represent the

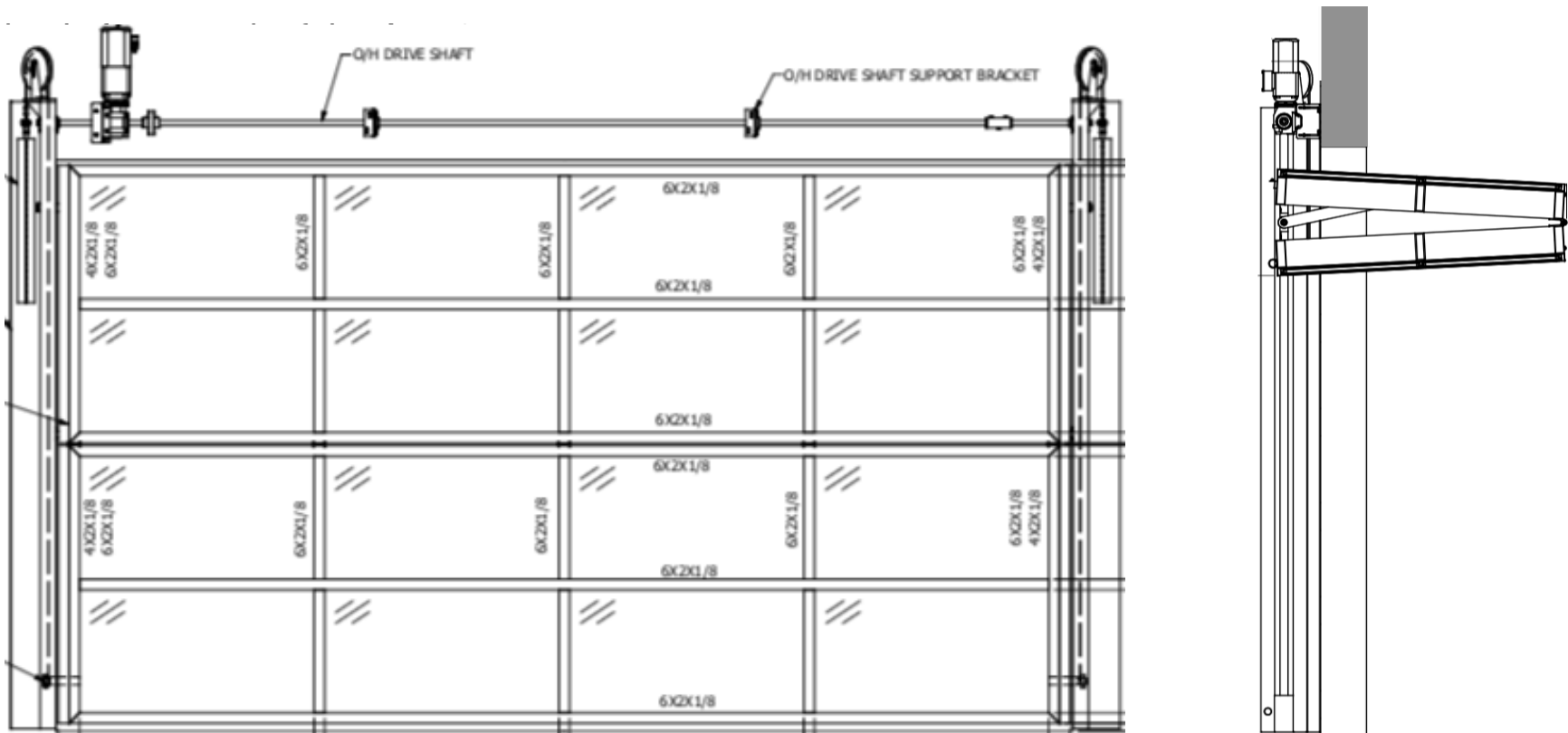

Table of Contents

Process 1- Preparations - 6

1. Bring these tools and materials
2. Examine the area
3. Set up a work zone
4. Prepare the pieces

Process 2- Positioning the Door-10

1. Set the door inside
2. Raise the door
3. Align the door
4. Connecting the cables

Process 3- Fastening the Operating Channels -15

1. Place the operating channels
2. Routing the cable

3.Connect the rails to the door

4.Fasten the operating channels

Process 4- Installing the Glass-19

1.Apply the tape and seat the glass panels

2.Insert the glazing caps

Process 5- Hanging the Counterweights and Balancing the Door-23

1.Hang the weights

2.Balance the door

Process 6- Engaging the Motor to the Door-26

1.Connect the trolleys

2.Install the torsion bar

3.Align the cam pins

Process 7- Installing the Threshold and the Top and Bottom Seals-28

1. Install the top seal
2. Install the bottom seal
3. Install the threshold

Process 8- Programming the Motor and Covering the Counterweights-31

1. Install and program the motor
2. Cover the counterweights
3. Test the door
4. Install physical stops into the motorized track
5. Troubleshooting-32

What you need to know before you begin:

- Only factory trained installers may install Full View doors because only they have the training to install them correctly, which is critical for quality and safety.
- Make sure you obtain and follow the shop drawings in each shipment because they alone specify each door's particular configuration. Do not begin an installation without them.
- Never substitute the hardware and components that Full View Door Company provides. If you need new parts, contact Full View Door Company at the number below.
- Use the appropriate tools, equipment, and personal protective gear to install the door so that you ensure a safe and quality installation.
- Contact Full View Door Company if you need technical support: 866-890-1776

Process 1- Preparations

1. Bring these tools and materials

- A. Tape measure
- B. Slip-ring pliers
- C. Rubber mallet
- D. Pull-type chain hoist
- E. Pry bar
- F. Power drill and drill bits- (Phillips, flat-head, sockets, etc.)
- G. Laser level or a long level (A laser level works best.)
- H. Sockets and wrenches
- I. Utility knife or sheers
- J. Wooden shims/ Plastic shims
- K. 1/4" rivet gun
- L. Heavy duty C-clamps
- M. Glazing suction cups

2. Examine the area

A. Compare the shop drawings to the doorway to ensure it has these things:

- a. A finished-door height that matches the drawings
- b. Space for the door to open and close without hitting the door or the ceiling's furnishings
 - c. Space in the doorway for the door
- d. Space for the counterweights to move without contacting other things
- e. Space for the cables to run without rubbing anything
- f. Space on the doorjamb and at the ceiling for the operating channels
- g. Doorjamb that are the same material as those in the shop drawings

3. Set up a work zone

A. Let other construction workers in the area know that the doorway will be inaccessible from the time you begin until you complete your installation. No one should run hoses or cords through the doorway because you will need total clearance.

B. Set up a safety zone according to the illustration.

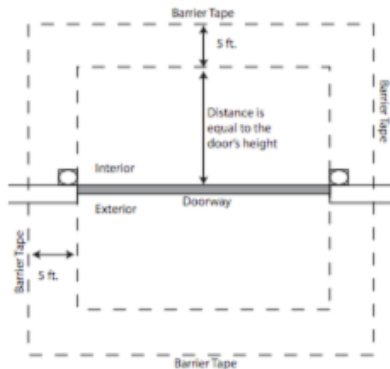

4. Prepare the pieces

A. Thoroughly examine the cables to make sure they are in good condition. Do not install them if they have any damage.

- B. Contact Full View Door Company if you need a replacement cable.!
- C. Place the counterweights and the operating channels inside the doorway.!
- D. Place the glass panels and glazing caps out of the way, if you have them, to protect them from damage.!
- E. Insert the side seals into the operating channels.
- F. Install the brass bushing into the operating channel with the loose cable thimbles inside the manual track. ***Refer to the picture below.***

NOTE: This door Frame is aluminum take precautions when moving the panels, and lifting into place.

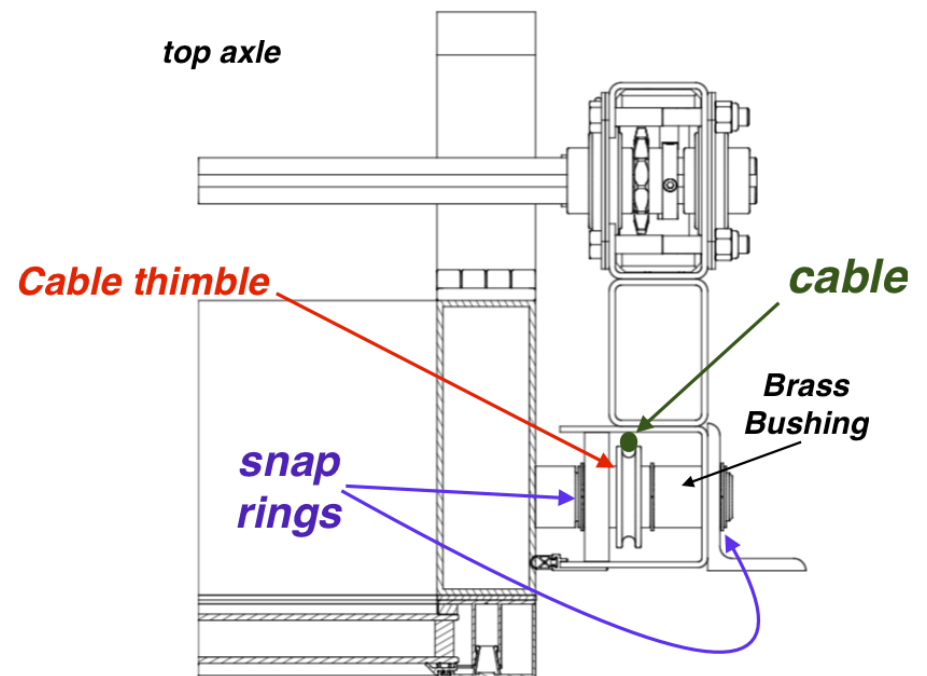

Process 2- Positioning the Door

1. Set the Door inside

A. Lift it from the shipping truck with a forklift by running straps or chains through the middle of the folded leaves, similar to the illustrations. Use a padding material with a chain so that it doesn't scratch the paint.

B. Place the door flat on the ground inside the doorway so that the axles are on the inside when you raise it.

C. Set the door on a soft material so that you will not to accidentally mar the finish.(E.g. cardboard or plywood)

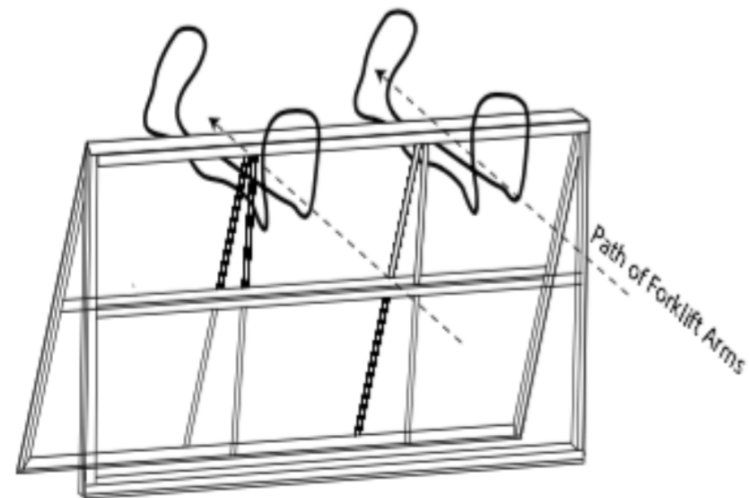
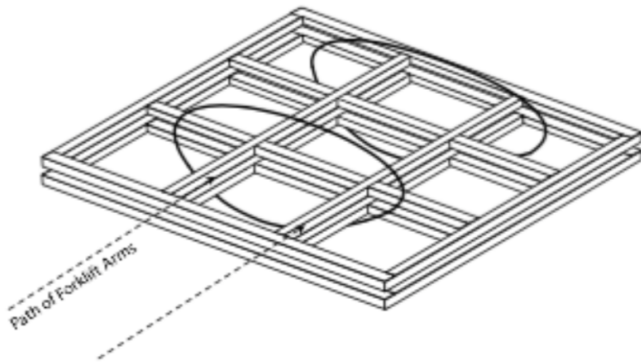

2. Raise the door

A. Place two counterweight plates in the opening (add adequate protection to protect to door frame) to give you space to level the door with shims after you raise it.

B. Use a chain hoist or a forklift to raise the door; use padding to protect the finish on the door.

*** CAUTION:** Ensure that the hoist or the forklift is rated to lift the door's weight.

C. Make sure the panels are vertically plumb. Insert shims between them, and clamp them so that they remain vertically plumb while you finish the installation.

(See the illustration below.)

D. Refer to the shop drawings to know how high off the finished floor the door needs to be.

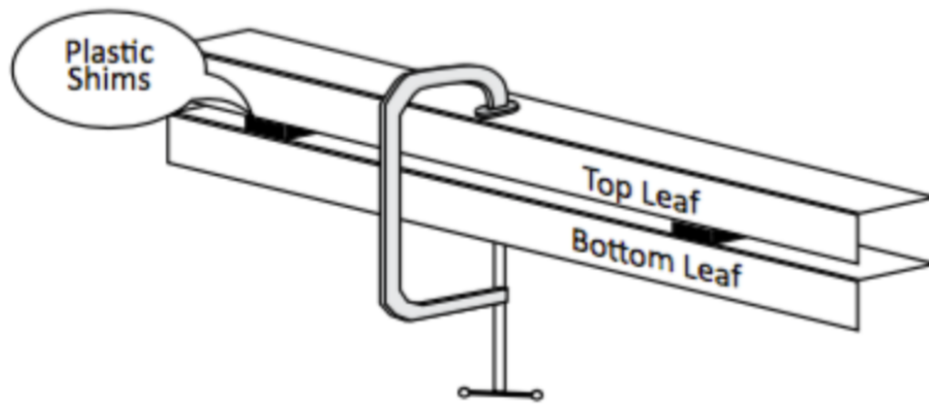

*NOTE: Make sure your clamps will not scratch the powder coating on the door,

or bend the aluminum frame.

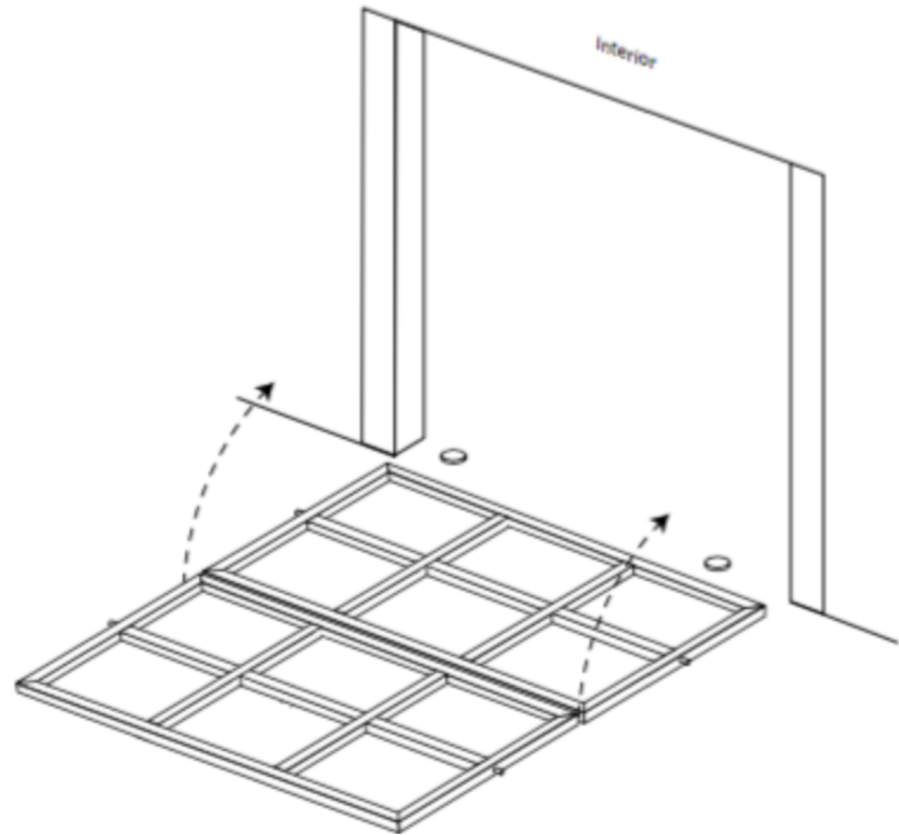

3. Align the Door

A. Install the door to the specific dimensions on the shop drawings, even if the floor is not finished.

* All dimensions in the shop drawings show the door's position relative to the finished floor.

B. Center the door so that it has equal spacing on the right and left. Make sure light does not shine through the side seals.

C. Level the door with a leveling device and shims.

D. The space between the bottom of the door and the finished floor must at least be what you see in the shop drawings.

E. Make sure the spacing on the top matches the shop drawings.

4. Connect the cables

- A. Lubricate the axles with the lubricant in the shipment, then join the cables, rollers, and slip rings to the axles on the bottom axle by following the sequence below.

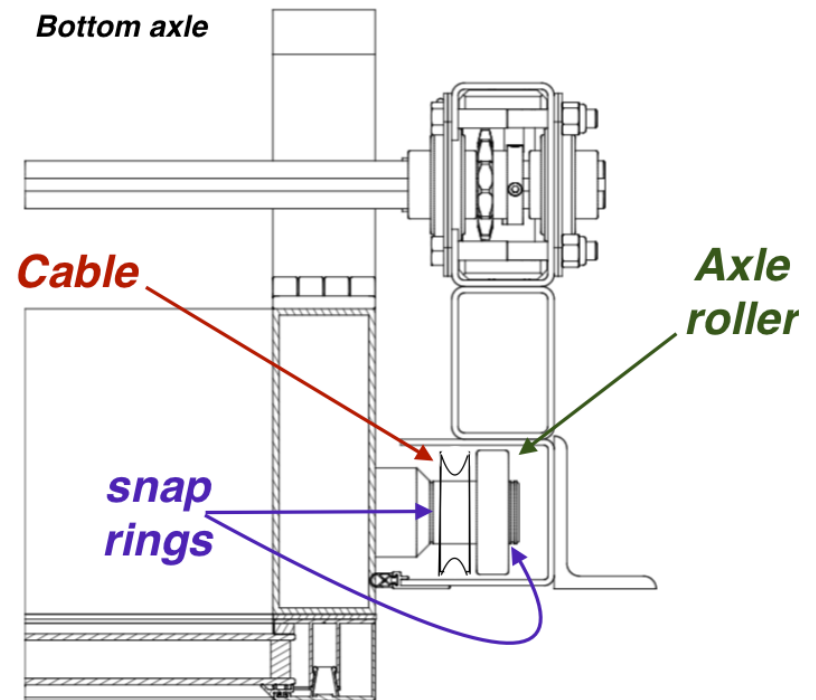

Process 3- Fastening the Operating Channels

1. Place the operating channels

A. With the Brass brushing and the loose cable thimble in the rail, stand the rail up and slide the rail onto the top axle. Position the rail to where the side seals on the operating channels are touching the door so that no light can shine through, but not so hard against it that the seals are compressed.

E. Adjust the operating channels, not the door, if the seals allow light to shine through.

2. Routing the cables

A. Route the cables through the channels of the rails and over the pulleys, according to the shop

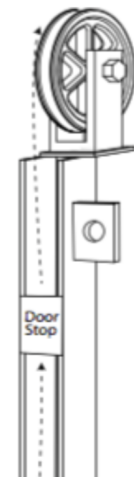

drawings.

B. If you are installing a set of doors that will share a counterweight, route the shared cable for one door, and after you have fastened its operating channels, route the cable for the second door. The cable will be draped between them for you to hang the counterweight from its center.

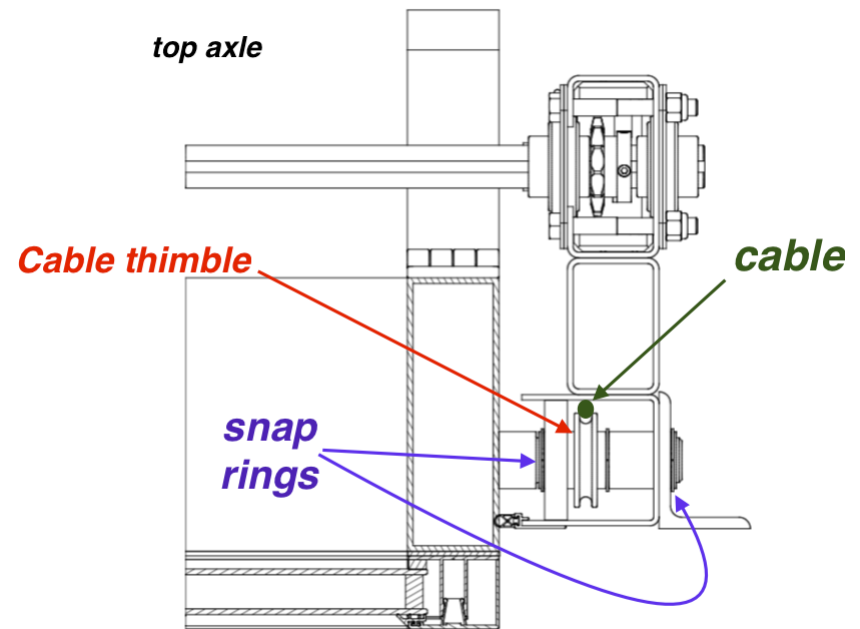

5. Fasten the Operating Channels

A. Use the hardware in the shipment to permanently mount the operating channels onto the doorjamb according to the shop drawings.

B. These illustrations show the standard methods for fastening the operating channels to wooden, steel, and concrete doorjamb. Refer to the shop drawings to know which applies to your installation.

For steel doorjamb-

Weld the top and side edges, and make the welds at least 1/4"

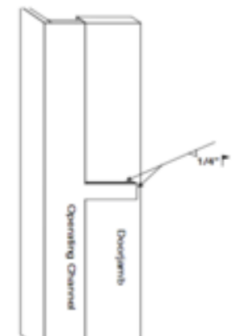

thick.

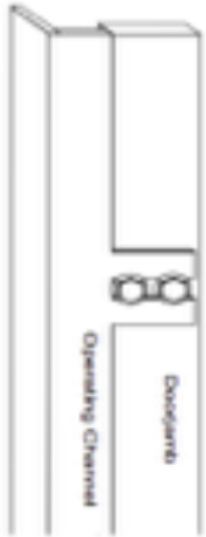

For wooden doorjamb-

Install the lag screws from the shipment according to this illustration; we will send washers in the shipment if the lag screws need them.

For concrete doorjamb-

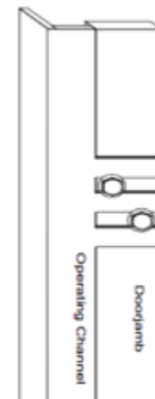

Install the anchors from the shipment according to this illustration; we will send washers in the shipment if the anchors need them.

Process 4- Installing the Glass (For doors with cladding, skip to Process 5)

1. Apply the tape and seat the glass panels

* NOTE: Only install the glass in dry weather and in temperatures above 40° Fahrenheit, or the tape will not adhere to the glass or the door.

A. Thoroughly wipe the areas where the tape will lie with denatured alcohol so that dust and moisture do not inhibit the tape's adhesiveness.

* NOTE: Do not substitute another adhesive in place of the tape in the shipment, unless the shop drawings indicate otherwise.

B. Apply the double-sided glazing tape to the inner edges of the mullions and to the frame where the panels will sit. Leave the protective film on the tape until you're ready to seat the panels. Do not lay the tape on a dirty surface because it will pick up dust.

C. Splices in the tape make the glass less likely to stick, so only splice the horizontal strips of tape where the mullions meet the frame and where the vertical cap grooves meet the mullions.

(See the circles in the illustration.)

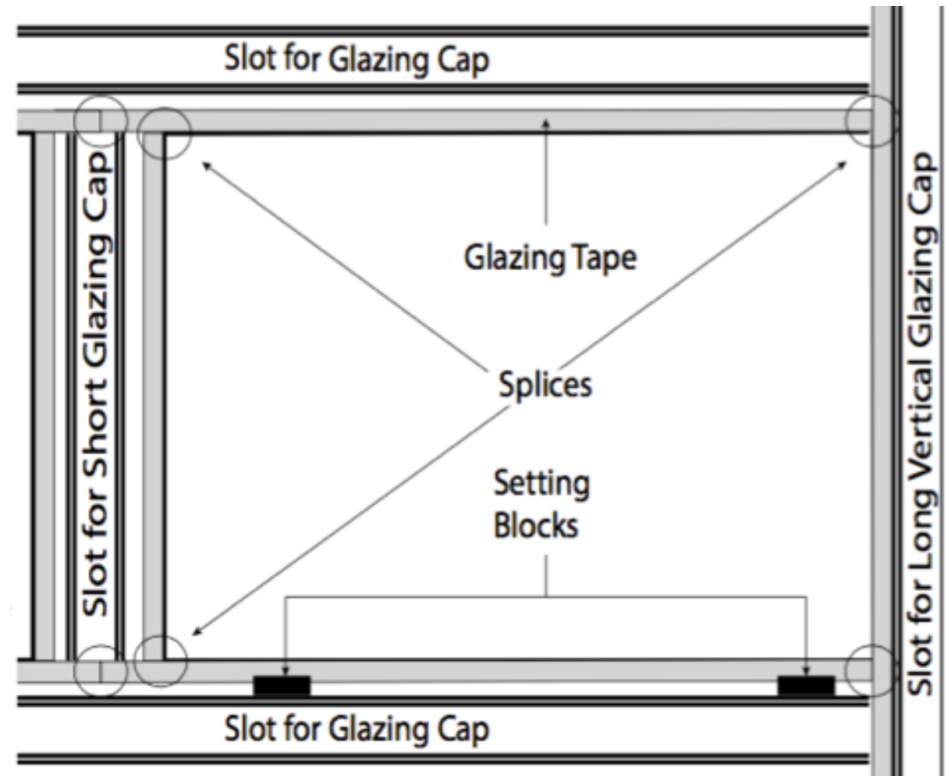

D. Apply the sealant in the shipment (Dow Corning 995 Sealant) to every splice in the tape, and place a setting block where each corner of the glass panels will sit.

E. Refer to the shop drawings to know which side of the glass should face the exterior.

F. Use suction cups to carry the glass panels, and seat them on the setting blocks. Press them firmly against the tape; the tape will adhere to the glass instantly.

G. Install the short glazing caps between the panels you have seated to hold them in place as you seat the others.

* NOTE: Make sure your suction cups are rated to carry the weight of the glass panels.

2. Insert the glazing caps

A. Trim the ends of the caps' seals at a 45° angle so that their seals will not push up the seals of the caps they intersect. (See the illustration on the side.)

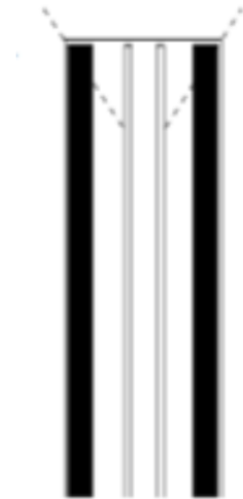

B. NOTE: Do not trim the caps because they have been fitted in the factory.

B. Cut a gap in the seals of the long, horizontal caps where the shorter caps will intersect them. Cut a similar gap in the seals of the long, vertical caps where the long, horizontal caps will intersect them. (See the circles in the illustration below.)

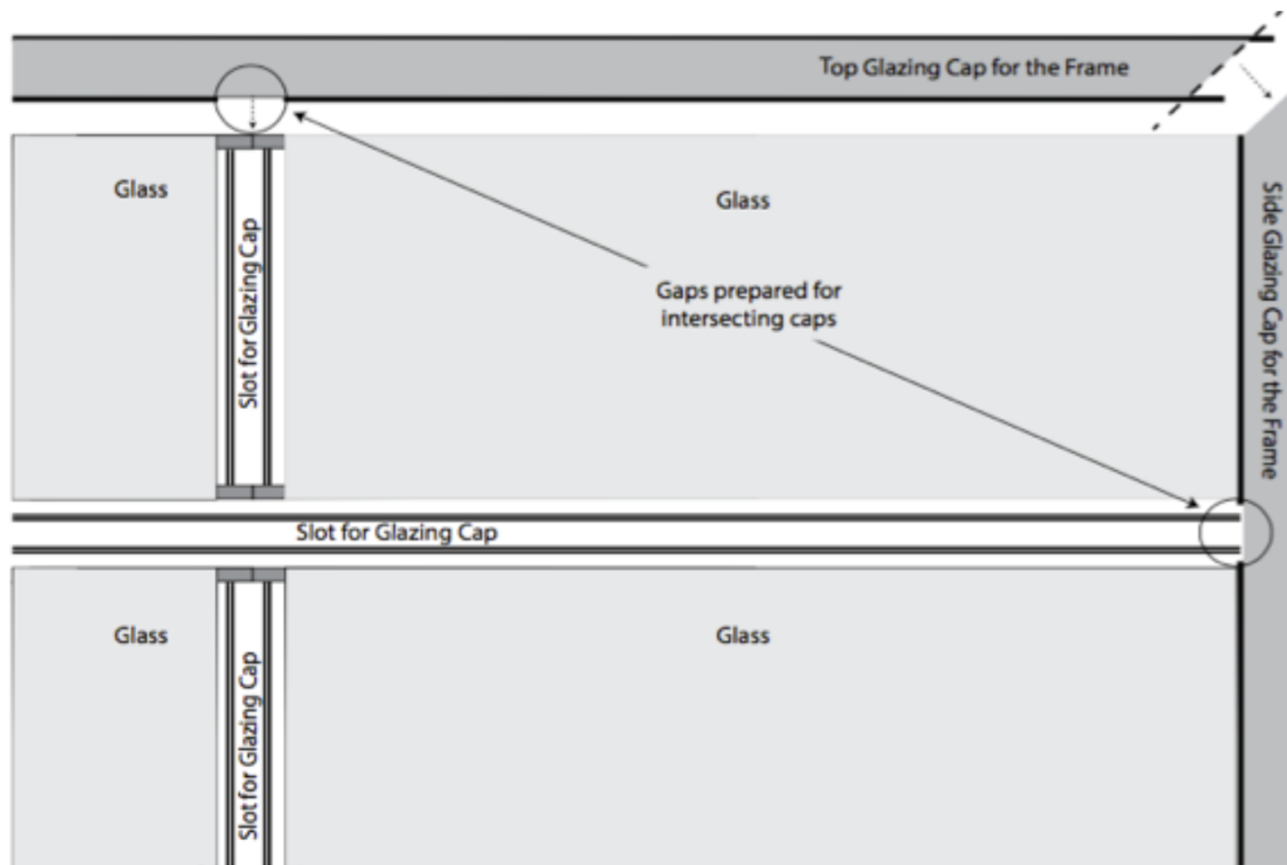

C. Install the caps by aligning their grooves to the inside of the mullions' grooves and tapping them in place with a rubber mallet. The caps will have labels to indicate their place on the door.

Process 5- Hanging the Counterweights and Balancing the Door

1. Hang the Weights

* CAUTION: You must install the glass (or cladding) before you hang the counterweights because they are designed to offset the weight of the door with its glass or cladding.

A. Refer to the shop drawings to ensure that you hang the weights properly.

B. Make sure to properly align the pulleys over the operating channels so that the cables do not rub anything after you hang the weights.

C. Use a chain hoist or a forklift to raise the counterweights to the ends of the cables.

D. Always bring the counterweights up to the cables, leaving the door closed. Never try to bring the cables down to the weights by opening the door.

* Welding a temporary lug on each of the weights gives your chain or strap something to catch as you raise the weight. (Cut off the lug after you hang the weights.)

* When hanging a shared counterweight, hang it in the middle of the shared cable, according to the shop drawings.

2. Balance the door

A. Remove the clamps that are holding the panels vertically plumb and the shims that are underneath the door so that you can open it.

* If the shims are wedged too tightly to slide out, and use a pry bar to lift the door high enough to slide them out.

* CAUTION: You must ground your welder directly to the counterweight that you are adding weight to so that the electrical current does not run through the cable and melt its core.

- B. To open the door manually, with the cam pins removed, push the hinge line toward the exterior. Then pull the bottom toward the interior, and slowly guide it upward until it gently rests in its open position. Close the door by gently pulling the bottom down until the door closes fully.
- C. Check the balance of the door by opening it halfway to see if it suspends without being inclined to open or close on its own.
- a. If the door closes on its own, the counterweights are not heavy enough, and you need to weld on extra plates.
 - b. If the door opens on its own, the counterweights are too heavy.
 - c. Also, the door is balanced if you can open and close it with the same amount of pressure.
- D. Fully open and close the door to ensure nothing hinders the counterweights or the door's travel. Fix any obstructions before you proceed.

* NOTE: Be careful not to allow the door to slam open or shut because that will eventually cause damage to the door, which may make it dangerous to use.

Process 6- Engaging the Motor to the Door

1. Connect the trolleys

A. With the door closed, insert the cam pins into the trolleys and insert the t-pins.

B. Slide each trolley up or down to where link arm fits onto both axles as shown in the picture.

C. Lock the arms into place by applying to correct snap ring to each axle.

* The motor will operate the door by the trolleys through the link arms.

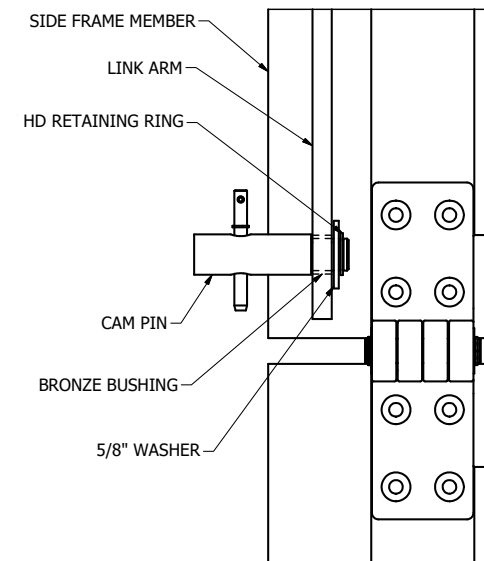
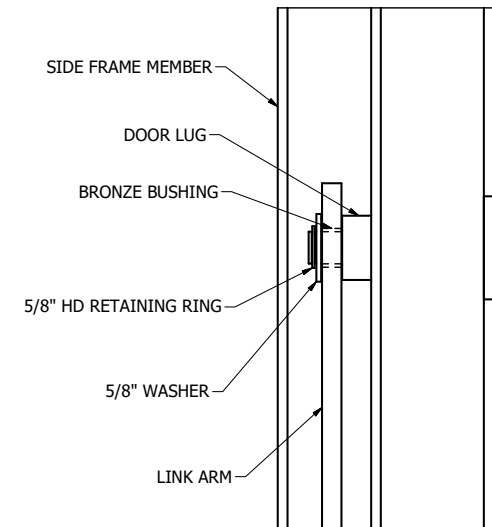

2. Install the torsion bar

A. Check the shop drawings to see its specifications for placing the motor and installing the torsion bar.

B. Cut the torsion bar to fit between the axles on the inner sides of the operating channels. (See the dotted line.)

C. Use the adjustment coupler, the fixed coupler, and the center support bracket to attach the bar to the axles. Level the bar before you secure it.

D. Install the adjustment coupler on the same side as the motor so that you do not have to move a ladder back and forth when you align the cam pins; and only slightly tighten the adjustment coupler because you will need to turn it by hand when you align the cam pins.

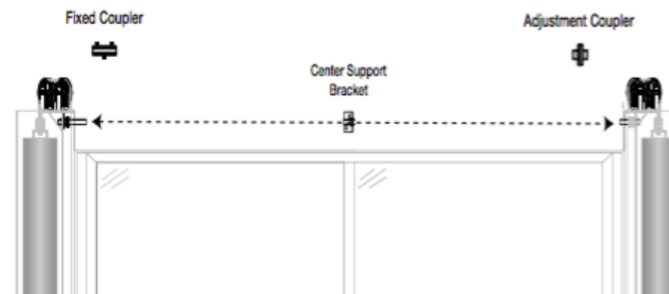

3. Align the cam pins

- A. To align the cam pins, make sure the door is plumb in the closed position. The link arms will set the distance down from the door.
- B. Using a laser level to time each side to the same height. You can accomplish this by rotating the adjustment coupler to move the trolley on that side up or down so that its cam pin is aligned with the other one.
- C. After you align the cam pins, tighten the adjustable coupler.

Process 7- Installing the Threshold and the Top and Bottom Seals

1. Installing the top seal

- A. Insert the gasket into the metal retainer
- B. Measure the top of the door for the retainer to fit snugly between the side seals. Cut the retainer and the 1/2 plate provided to the Measurement taken.

C. Apply a small bead of caulk to the no counter bored side of the 1/2 plate and sit the plate in the desired location behind the header. Using the screws provided attach to the top of the door.

D. Attach the retainer into the top of the door frame on top of the 1/2 plate in line C .according to the illustration. Make sure no light penetrates between the top and side seals.

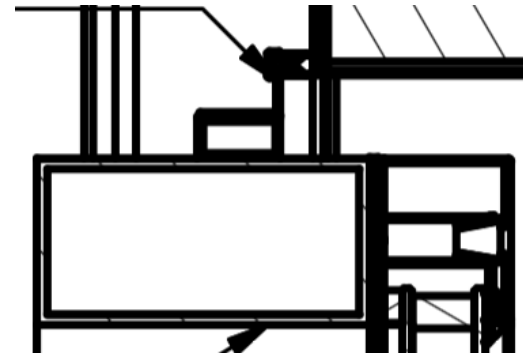

2. Install the bottom seal

A. Install the bottom seal by opening the door to access the bottom of the frame, and install the seal according to the drawings below.

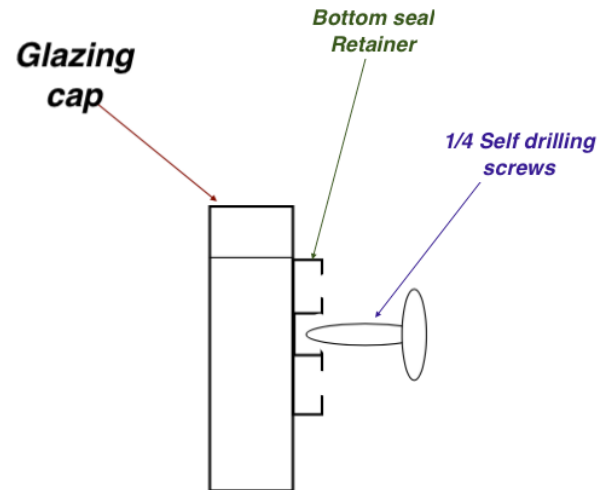

3. Install the threshold

A. Measure the opening between the jambs, and cut the threshold 3 inches longer than the opening.

B. Cut a 1 inch notch out of the short side on the ends of the threshold. Seat the notches of the threshold on the interior corners of the doorjambs, and operate the door to make sure the bottom seal and the hump on the threshold make good contact without inhibiting the door's movement.

C. Through each of the predrilled holes in the threshold drill pilot holes in the floor for the screws. Move the threshold, and apply a bead of structural adhesive that is $\frac{5}{16}$ of an inch thick between the pilot holes where the threshold will lie.

D. Place the threshold in its position, and seat the screws.

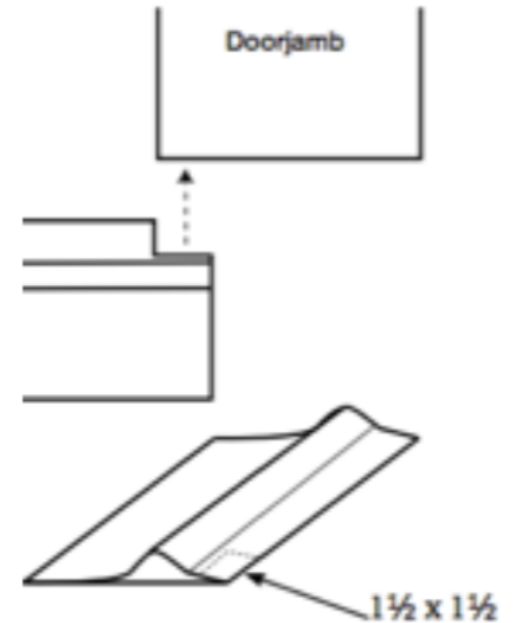

* NOTE: If you need to splice the threshold, join the pieces where screws will be no more than 8 inches from both sides of the splice.

Process 8- Programming the Motor and Covering the Counterweights

1. Install and program the motor

- A. Install the motor as the shop drawings specify.
- B. Program the motor according to its installation manual.
- C. Ensure that the motor closes the door vertically plumb.

2. Cover the counterweights

- A. Follow the shop drawings to see how to install the covers for the counterweights.
- B. Making sure you have the correct weight cover for each side of the door.

3. Test the door

- A. Operate the door 5 to 10 times to ensure it works properly.
- B. Ensure that the seals are making good contact and that the door closes and opens to the dimensions in the shop drawings.

Troubleshooting

A. The door is difficult to open or close.

- a. Check the balance of the door and the counterweights; add or remove weight to the counterweights if it's necessary.
- b. Inspect the perimeter seals, and verify that they are not causing excessive friction.
- c. Ensure that the counterweights can travel without contacting anything.

B. The door stops and returns to the open position when I try to close it.

- a. Make sure that nothing is obstructing the motor's safety
- b. Check the motor's control panel because it may indicate the problem. Refer to the motor's installation manual for a diagnosis
- c. Make sure the wiring in the control station is correct.

C. The door stops and returns to the closed position when I try to open it.

- a. Make sure the cam pins are aligned; loosen the adjustment coupler on the torsion bar if you need to realign them. (See Process 6, number 3)

D. The door will not operate.

- a. Verify that power is getting to the motor and/or its control unit.
- b. Check the wiring in the control station.
- c. Make sure the photo eyes are connected and working
- d. Make sure the motor is engaged to the torsion bar.

C. The door makes a "bumping" noise when I operate it.

- a) Lubricate the surfaces between the cable thimbles and the axles with bearing grease.
- b) Make sure the trolley chains have a little deflection in them.
- c) Adjust each chain's tension by turning the turnbuckle that connect the trolleys to the chains.
- d) Inspect and lubricate the pulley bearings.

D. The Door Does Not Close Completely.

- A. Check the settings for the travel limit that the motor calibrated.
- B. Make sure nothing is binding the bottom seal.
- C. Make sure the bottom of the door is not rubbing the floor.

E. The door does not open completely

- a. Check the door stops to make sure the door is meeting them and opening fully. (See Process 3, Step 2 to indicating the location of the door stop.)

- b. Make sure the door is not colliding into the lintel.
- c. Make sure nothing is keeping the counterweights from lowering fully.

H. ZAP Motor is operating very slow.

- a. The motor may still be calibrating the door's movement. Refer to the motor's manual for reset instructions and limit programming.
- b. Make sure nothing is obstructing the door.
- c. In the event of power loss for more than 2 hours, the internal memory module will need to recalibrate the door's limits. Operate the door to fully open and fully closed, and the motor will resume normal operation.

F. Service and Repair

- 1. Replacing a glass panel
 - a. From the outside, one person should hold the panel with suction cups.

2. From the inside, another person should cut the double- sided tape by sliding a utility knife around the edges of the panel, releasing it for the person on the outside to remove.
3. Thoroughly clean the mullions with denatured alcohol, scraping the excess residue if it's necessary. Do the same on the glass panel if you intend to reuse it.
4. Reapply the tape according to the instructions in Process 4.

2. Replacing the trolley

- a. Slide the trolley up to the service port at the bottom of the operating channel.
- b. Disconnect the trolley from the chain by unscrewing the tensioner turnbuckle and unhinging the chain link at the top.
- c. Remove the U-shaped fastener from the chain link so that you can slide the chain pin out of the trolley's tab. (See the illustration.)
- d. Pull the trolley out at the top of the channel.

- e. Remove the worn pads by removing the screws.
- f. Reinsert the trolley into the channel, and reconnect the tensioner bolt and the chain link.
- g. Adjust turnbuckle to tension chain.(Correct tension is when you can pinch the chain together inside the track, and chain should just touch.)

